

CONTINENTAL



HYDRAULICS

CONTINENTAL HYDRAULICS

VSD03M-EXA

HAZARDOUS DUTY SOLENOID ACTUATED, DIRECT OPERATED

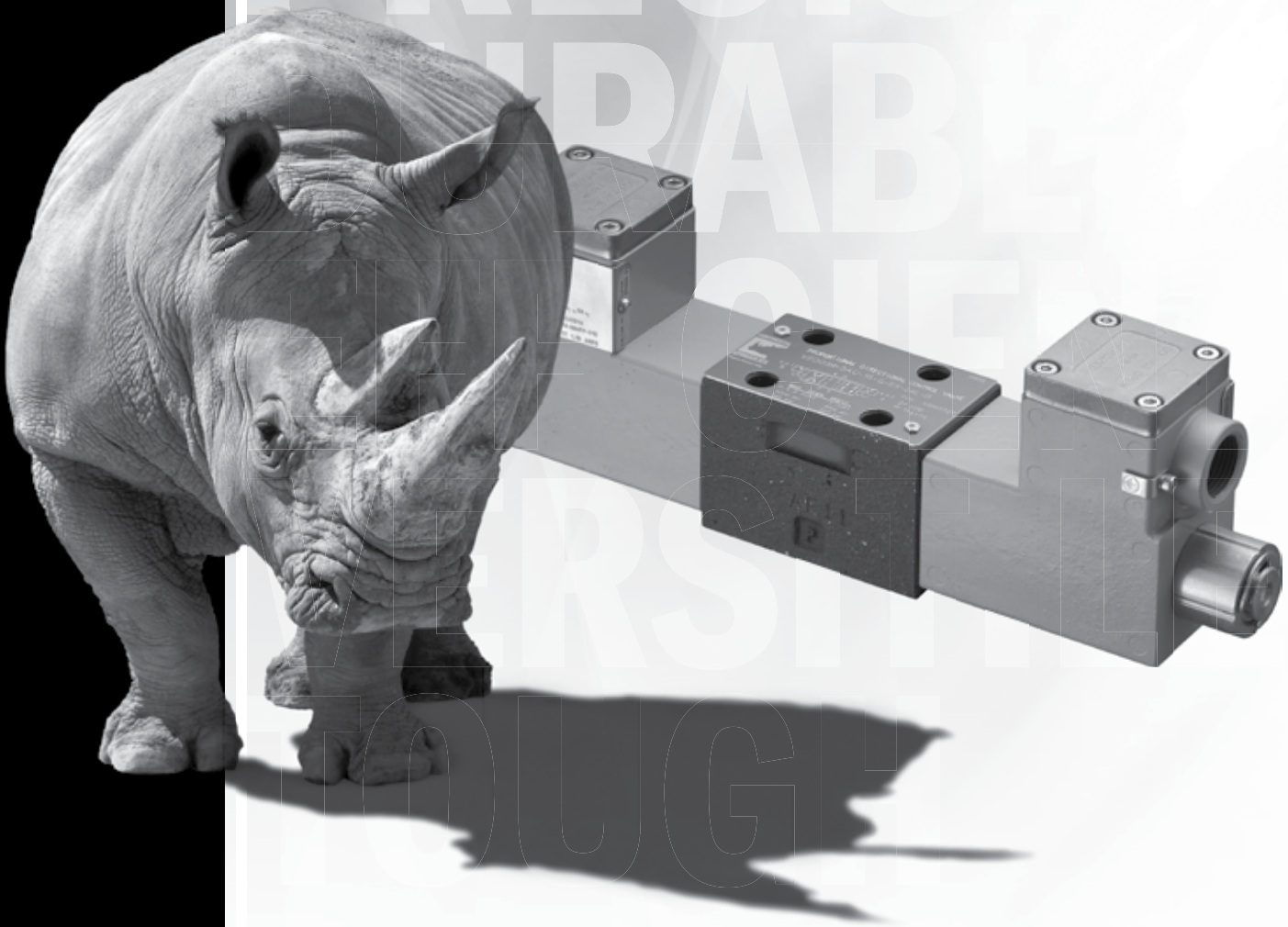

VSD03M-EXA - HAZARDOUS DUTY SOLENOID ACTUATED, DIRECT OPERATED

VSD03M-EXA

HAZARDOUS DUTY SOLENOID ACTUATED, DIRECT OPERATED

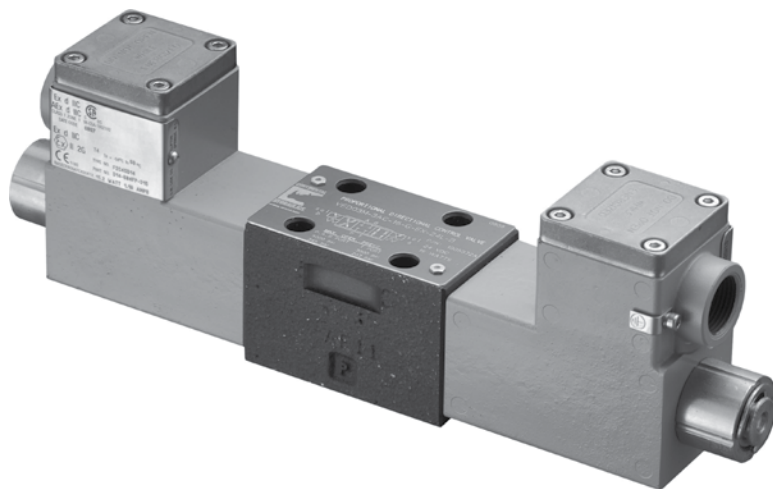

DESCRIPTION

The solenoid operated directional control valves are in compliance with ATEX 94/9/CE standards and are suitable for the use in potentially explosive atmospheres, that fall within either the ATEX II 2GD for gas or for dust classification.

CERTIFICATE NUMBER: CEC II ATEX 076

OPERATION

Continental's line of explosion proof, 4-way, directional control valves is available in 2 position spring offset, 2 position detent, 2 position spring centered and 3 position spring centered versions. Four spools are available: block center, open center, float center and tandem center.

The explosion proof solenoids are available in 12 VDC, 24VDC and 120VAC. The AC coil is equipped with a rectifier bridge. The DC coils have a built-in bi-directional diode for surge suppression.

TYPICAL PERFORMANCE SPECIFICATIONS

MAXIMUM OPERATING PRESSURE	P - A - B Ports	5000 psi	350 bar
	T Port	3000 psi	210 bar
MAXIMUM FLOW RATE		20 gpm	76 l/min
MOUNTING SURFACE		NFPA D03 ISO 4401-03-02-0-03	
CYCLE RATE	DC Solenoid	Up To 18,000 cycles/hr	
WEIGHT	DC Single Solenoid	5.3 lbs	2.4 kg
	DC Dual Solenoid	8.6 lbs	3.9 kg

RANGE TEMPERATURES (SEE NOTE)	Ambient	-4 to +140 °F	-20 to +60 °C
	Fluid	-4 to 176 °F	-20 to +80 °C
FLUID VISCOSITY	Range	60-1900 SUS	10-400 cSt
	Recommended	120 SUS	25 cSt
FLUID CONTAMINATION		ISO 4406:1999 Class 20/18/15	

NOTE:

A version resistant up to - 40 °F (- 40°C) is available upon request.

IDENTIFICATION CODE

VSD03M - [] [] - [] [] - **EXA** - [] **L** - [] _____ DESIGN LETTER

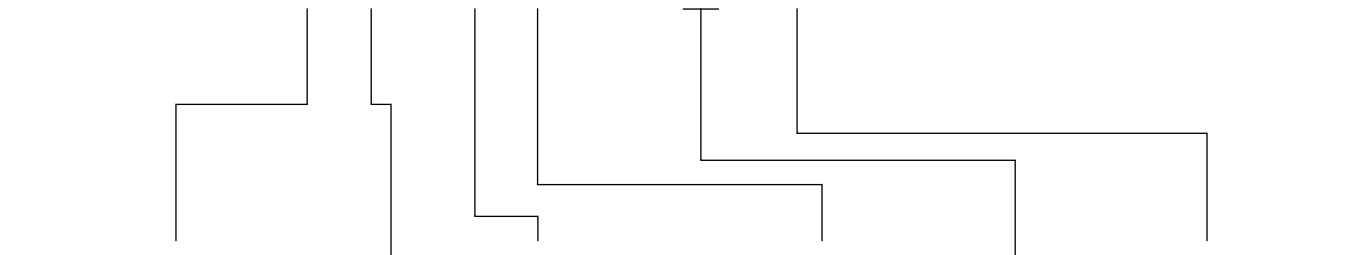

FUNCTION	
1	
	Single Operator 2 Position Spring Offset
2	
	Dual Operator 2 Position Detented (No Spring)
3	
	Dual Operator 3 Position Spring Centered
5	
	Single Operator 2 Position Spring Centered

SEAL	
A	Buna (STD)
G	Viton

Spool Type
See Next Page

MECHANICAL OMIT IF NOT REQUIRED	
R	Single Solenoid 'B' Port End. Available Only With Function 1 And 5.

SOLENOID	
130	120 V AC- 60 Hz With Built-In Rectifier
137	24 V DC
138	12 V DC

CERTIFICATION	
A	94/9/EC Directive (ATEX)

TYPICAL ORDERING CODE:
VSD03M-3A-A-EXA-137L-C

VSD03M-EXA - HAZARDOUS DUTY SOLENOID ACTUATED, DIRECT OPERATED

SPOOLS						
NAME	SYMBOL	FUNCTION	CENTER POSITION	CROSSOVER	FUNCTION MATCHING	
A			All ports blocked	P→B or P→A T blocked	1, 2, 3, 5	
A1			All ports closed	P→B and A→T restricted or P→A and B→T restricted	3, 5	
B			All ports open	All ports open	1, 2, 3, 5	
E			P and A blocked, and B→T	All ports blocked or P and A blocked and B→T	3, 5	
E1			P and A blocked, B restricted to T	All ports blocked or A blocked and B→T restricted		
F			P blocked, A→T and B→T	P blocked and A→T or B→T		
F1			P blocked, A and B restricted to T	P blocked, A or B restricted to T		
G			P to A and B T blocked	P→B or P→A T blocked		
H			P and A to T, B blocked	All ports open, restricted		
J			P→B A and T blocked	P→B and A blocked or all port blocked		
K			P and B blocked, and A→T	P and B blocked and A→T or all ports blocked		
K1			P and B blocked, A restricted to T	P blocked and A→T restricted or all ports blocked		
L			P→T, A and B blocked	All ports open, restricted		
N			P→A B and T blocked	All ports blocked, or P→A B and T blocked		
Q			P and B to T, A blocked	All ports open, restricted		
X			-	All ports blocked		2
AN			-	All ports blocked		2
AJ			-	All ports blocked		2

These are the standard configurations. Contact Continental Hydraulics for special versions.

PERFORMANCE CURVE

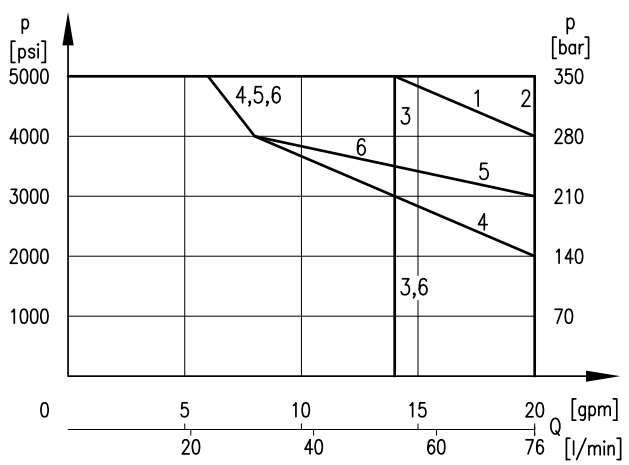

CURVE	SPOOLS
1	A
2	2A, A1, AN, AJ, E1, F1, K1, G, J, N, X
3	B, E, K, H, L, Q
4	F
5	1A
6	1B

NOTES:

1. The values indicated in the graphs are relevant to the standard solenoid valve, with 137L coils.
2. Valve performance was tested in a four way circuit (full loop). Performances may be reduced from that shown when used in a three-way circuit (half circuit), i.e. A or B port plugged.
3. The values have been obtained according to ISO 6403 norm with solenoids at rated temperature and supplied with voltage equal to 90% of the nominal voltage. The value have been obtained with filtration according to ISO 4406:1999 class 18/16/13.

PRESSURE DROPS Δp -Q (OBTAINED WITH VISCOSITY OF 170 SUS (36 cSt) AT 122°F (50°C))

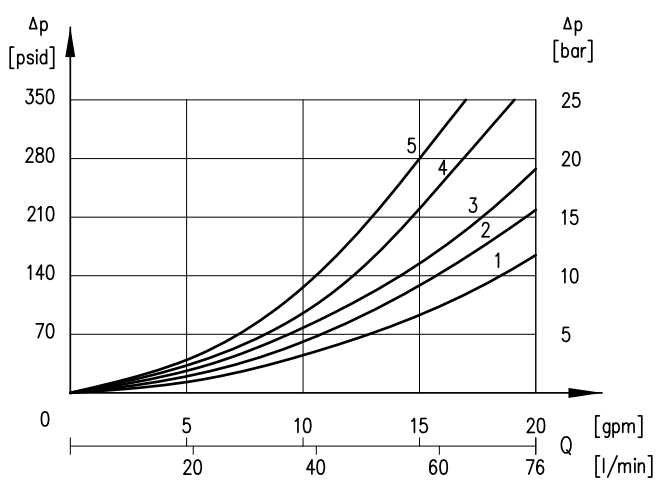

SPOOL	FLOW CURVE NUMBER				
	SHIFTED				CENTERED
	P→A	P→B	A→T	B→T	P→T
A, A1, K1, F1, E1	2	2	3	3	
B	1	1	3	3	2
E	2	2	3	1	
F	3	3	1	1	
G	1	3	1	3	
H, Q	4	5	5	5	3
J	2	1	3	3	
K	2	2	1	3	
L	5	5	5	5	3
N	1	2	3	3	
1A, 2A, 2AN, 2AJ	3	3	3	3	
1A, 1B, 2A	2	2	2	2	
9X	3	3			

SWITCHING TIMES

TIMES (±10%) [ms]	
ENERGIZING	DE-ENERGIZING
60	45

NOTE:

Switching times obtained with 1A solenoid valve with Q = 6.6 gpm (25 l/min) and p = 2150 psi (150 bar).

The energizing time is obtained at the time the spool switches over. The de-energized time are measured at the time pressure variation occurs on the line.

OVERALL AND MOUNTING DIMENSIONS

VSD03M - 2*, 3*

Dimensions in mm [IN]

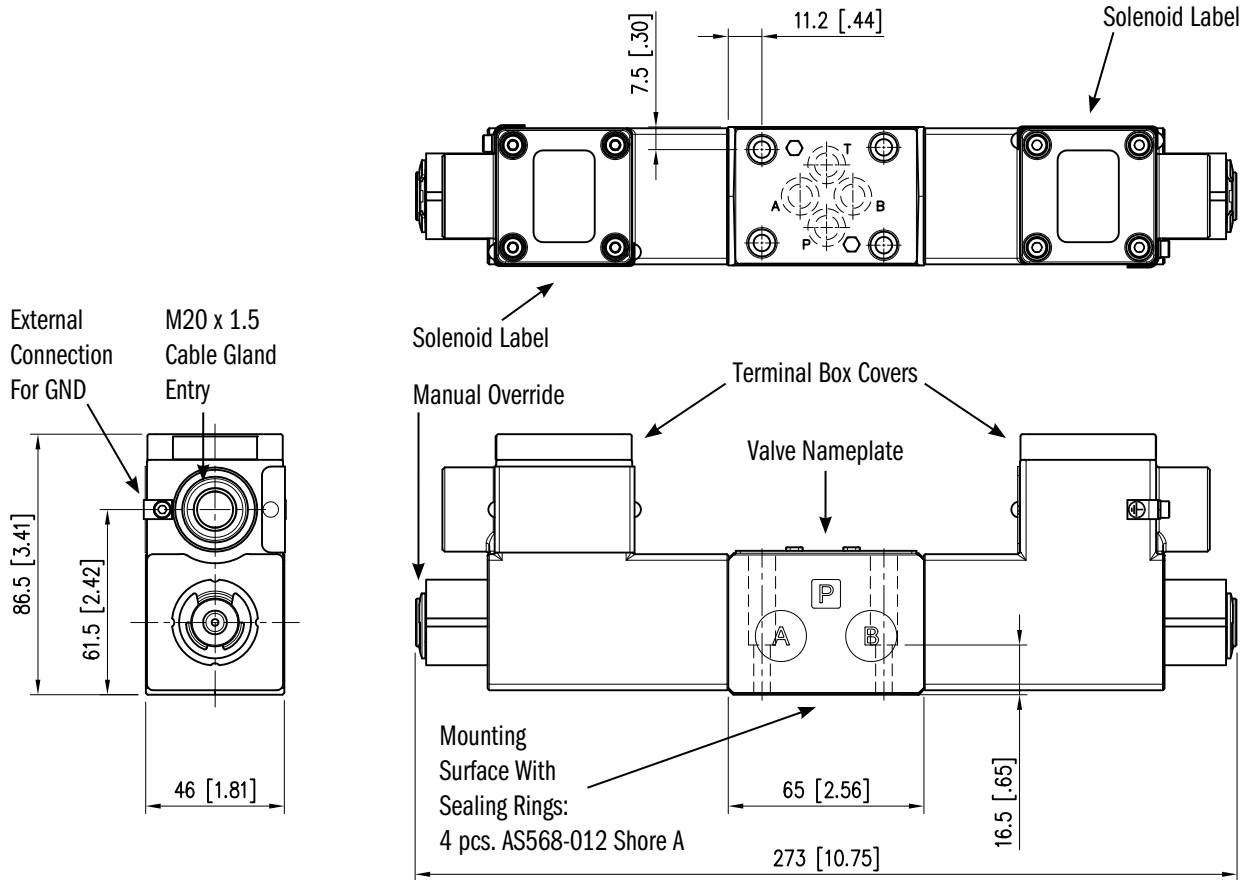

VSD03M - 1*, 5*



Do not remove the cover from the coils while energized.

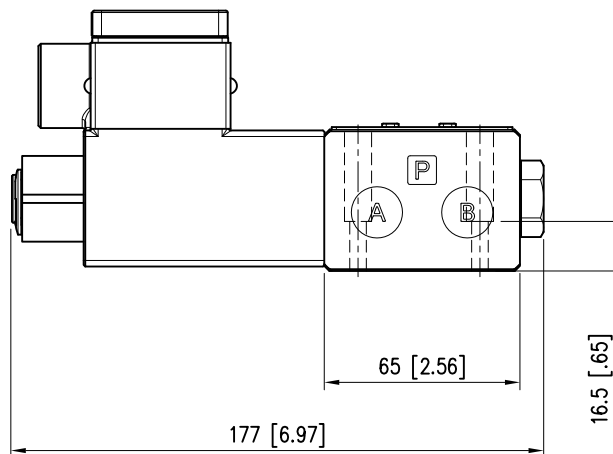

HAZARDOUS DUTY

CLASSIFICATION

The valves can be used for applications and installations in potentially explosive atmospheres that fall within either the ATEX II 2G or the ATEX II 2D classification.

- Group: II (Surface Plants)
- Category: 2 (High Protection For Areas 1 and 2)
- Type of Atmosphere:
 - G (Explosive Atmosphere With Gas Or Vapours)
 - D (Explosive Atmosphere With Dust)

SOLENOIDS

These are essentially made up of two parts: tube and coil. The tube is threaded onto the valve body and includes the armature that moves immersed in oil, without wear. The inner part, in contact with the oil in the return line, ensures heat dissipation.

The coil is fastened to the tube by a retainer provided with anti-unlocking safety bowed retaining ring.



The 'D' type of mechanical construction of the coil housing is made in order to ensure its resistance to possible internal explosion and to avoid any explosion propagation to the outside environment.

Moreover, the solenoid is designed to maintain its surface temperature below the limits specified to the relevant class.

VALVE - TYPE OF PROTECTION

RANGE OF APPLICATION AS PER DIRECTIVE 94//9/EC	II 2GD
TEMPERATURE CLASS	T4 (Surface Temperature ≤ 135°C)

SOLENOID - TYPE OF PROTECTION

EN 60079-0:2006 EN 60079-1:2007	Ex d IIC  IIB0  II 2G
EXAMINATION CERTIFICATE:	BASEEFA08ATEX004IX
CSA 22.2 N° 60079-0. 07 N° 60079-1. 07	 Ex d I I C, AEx d IIC for class I zone I
UL60079-0.05 UL60079-1.05	
EXAMINATION CERTIFICATE:	08-CSA-1932102

CLASS OF PROTECTION FOR INSULATION :	Copper Wire	Class H (356°F)
	Coil	Class H (356°F)

VALVE - ELECTRICAL DATA

SUPPLY VOLTAGE FLUCTUATION	±10 % Vnom	
MAX SWITCH ON FREQUENCY	18,000 cycles/hr	
DUTY CYCLE	100%	
ELECTROMAGNETIC COMPATIBILITY (EMC)	According to 2004/108/EC	
IP DEGREE	IEC EN 60529	IP 65

CURRENT AND POWER CONSUMPTION

The table shows current and power consumption values relevant to the different coil types, for direct or alternating 50 or 60 Hz current supply. Code 130L coil must be used when the valve is fed with AC power supply and then rectified by means of the rectifier bridge incorporated into the coil.

COIL TYPE	VOLTAGE	ABSORBED CURRENT A (± 5%)	POWER W (± 10%)
130L	120 V AC- 60 Hz	0.188	20
137L	24 V DC	0.54	13
138L	12 V DC	1.02	12.5

WIRING PRACTICES

TOP VIEW OF COIL FOR WIRING

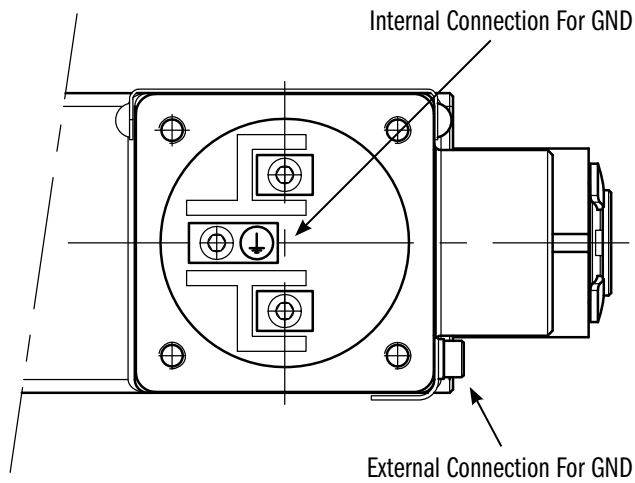

A cable entry hole is provided to accommodate any suitable certified flameproof cable entry device. Cable entry temperature may exceed 158 °F (70 °C).

Connect external ground where required. (North American applications - external ground connections: Use where local codes or authorities permit or require external ground connections.)

Remove the terminal box cover and connect electrical supply and ground to terminal block, torque to 0.23 - 0.90 Nm (2-8 lb.in).

AWG 16 for all internal connections.

NOTE: Coil is polarity insensitive.

Replace cover and secure with the 4 screws with lock washers, torque to 1.7 Nm (1.25 lb.ft).

WIRING DIAGRAM FOR DC

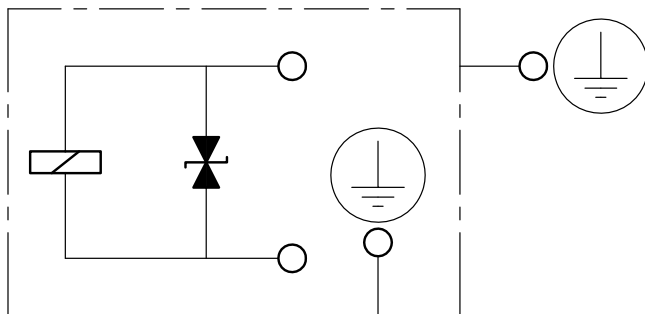

NOTE:

The circuit is provided with a surge suppressor: A component designed to dissipate the coil energy to protect circuit components.

APPLICATION DATA

FLUIDS

All pressure drops shown on these data pages are based on 170 SUS fluid viscosity and 0.87 specific gravity. For any other specific gravity (G1) the pressure drop (ΔP) will be approx. $\Delta P1 = \Delta P (G1/G)$. See the chart for other viscosities.

FLUID	Cst	10	14.5	32	36	43	54	65	76	86	108	216	324	400
VISCOSITIES	SUS	60	75	150	170	200	250	300	350	400	500	1000	1500	1900
MULTIPLIER		0.77	0.81	0.97	1.00	1.04	1.10	1.15	1.20	1.24	1.31	1.56	1.72	1.83

INSTALLATION

The configurations with centering and return springs can be mounted in any position. Valve fitting takes place by means of bolts or stud kits, fixing the valve on a lapped surface, with values of planarity and smoothness that are equal to or better than those indicated in the drawing. If the minimum values of planarity or smoothness are not met, fluid leakages between valve and mounting surface can easily occur.

Valves are fixed by means of screws or tie rods on a flat surface with planarity and roughness equal to or better than those indicated in the relative symbols. If minimum values are not observed, fluid can easily leak between the valve and support surface.

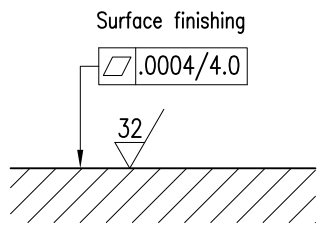

BOLT KIT

BD03-100	Valve only	121472
-----------------	------------	--------

NOTES:

1. Bolt Kit Consists Of: 4 pcs. 10-24NC Fasteners
4 pcs. #10 Lock Washer
2. Tightening Torque: 5 - 7 Nm [4 - 5 lb.ft]

SEAL KIT

VSD03M-EXA Buna Seal Kit	1013275
VSD03M-EXA Viton Seal Kit	1013276

VSD03M-EXA - HAZARDOUS DUTY SOLENOID ACTUATED, DIRECT OPERATED

POWERFUL
ACCURATE
INNOVATIVE
PRECISE
DURABLE
EFFICIENT
VERSATILE

ABOUT CONTINENTAL HYDRAULICS

Rugged, durable, high-performance, efficient—the reason Continental Hydraulics' products are used in some of the most challenging applications across the globe. With a commitment to quality customer support and innovative engineering, Continental's pumps, valves, power units, mobile and custom products deliver what the markets demand. Continental has been serving the food production, brick and block, wood products, automotive and machine tool industries since 1962. Learn how our products survive some of the most harsh environments.

SALES@CONTHYD.COM

5505 WEST 123RD STREET • SAVAGE, MN 55378-1299 / PH: 952.895.6400 / FAX: 952.895.6444 / WWW.CONTINENTALHYDRAULICS.COM

FORM NO. 1013268. REV. 12/2011. © 2011 CONTINENTAL HYDRAULICS. ALL RIGHTS RESERVED. PRODUCT SPECIFICATIONS AND APPEARANCE ARE SUBJECT TO CHANGE WITHOUT NOTICE.

CONTINENTAL



HYDRAULICS.