

CONTINENTAL



HYDRAULICS

CONTINENTAL HYDRAULICS

VSD * M-VPD * M

PILOT OPERATED DIRECTIONAL VALVES



VSD * M-VPD * M - PILOT OPERATED DIRECTIONAL VALVES

VSD*M-VPD*M

PILOT OPERATED DIRECTIONAL VALVES

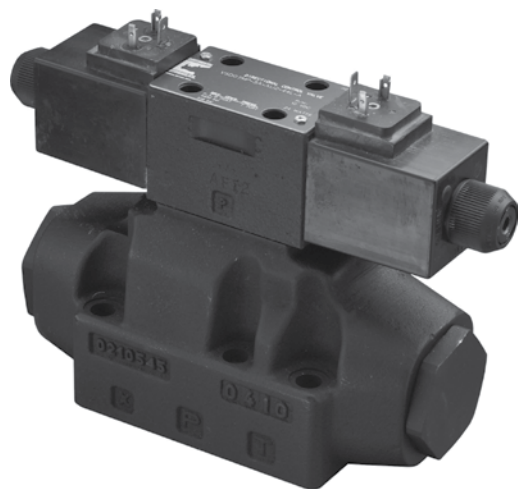

DESCRIPTION

The VSD*M and VPD*M pilot operated directional control valves are available with either electric solenoid or hydraulic actuation of the main spool.

Available in 5 standard NFPA and ISO patterns, these pilot operated valves are used in applications requiring high flow rates.

OPERATION

The valves are available in both 2 or 3 position and various spool flow patterns.

On VSD*M valves, the configuration for internal or external pilot/drains can be easily changed in the field. Also available to improve consistent cycling of the valve are pilot pressure reducing, pilot chocks, and main stage stroke adjustments.

TYPICAL PERFORMANCE SPECIFICATIONS

		VSD05*M		VSD07M		VSD08M		VSD10M	
MAXIMUM OPERATING PRESSURE	P - A - B Ports	4600 psi	320 bar	5000	350 bar	5000 psi	350 bar	5000 psi	350 bar
	T Port (Ext. Drain)	3600 psi	250 bar	3600 psi	250 bar	3000 psi	210 bar	3000 psi	210 bar
	T Port (Int. Drain)	2000 psi	140 bar	2000 psi	140 bar	2000 psi	140 bar	2000 psi	140 bar
	X Port	3000 psi	210 bar	4000 psi	280 bar	5000 psi	350 bar	4000 psi	280 bar
MINIMUM PILOT PRESSURE		72 psi	5 bar	170 psi	12 bar	72 psi	5 bar	170 psi	12 bar
MAX FLOW RATE		40 gpm	150 l/min	80 gpm	300 l/min	125 gpm	473 l/min	290 gpm	1100 l/min
MOUNTING SURFACE		NFPA D05 alt. A /alt. B ISO 4401-05-05-0-05		NFPA D07 ISO 4401-07-07-0-05		NFPA D08 ISO 4401-08-08-0-05		NFPA D10 ISO 4401-10-09-0-05	
WEIGHT		19 lbs	8.6 kg	19.4 lbs	8.8 kg	34 lbs	15.4 kg	110 lbs	50 kg

IDENTIFICATION CODE - SOLENOID OPERATED

VSD **M** - - - - - - - - - - - - - **L** - ——— DESIGN LETTER

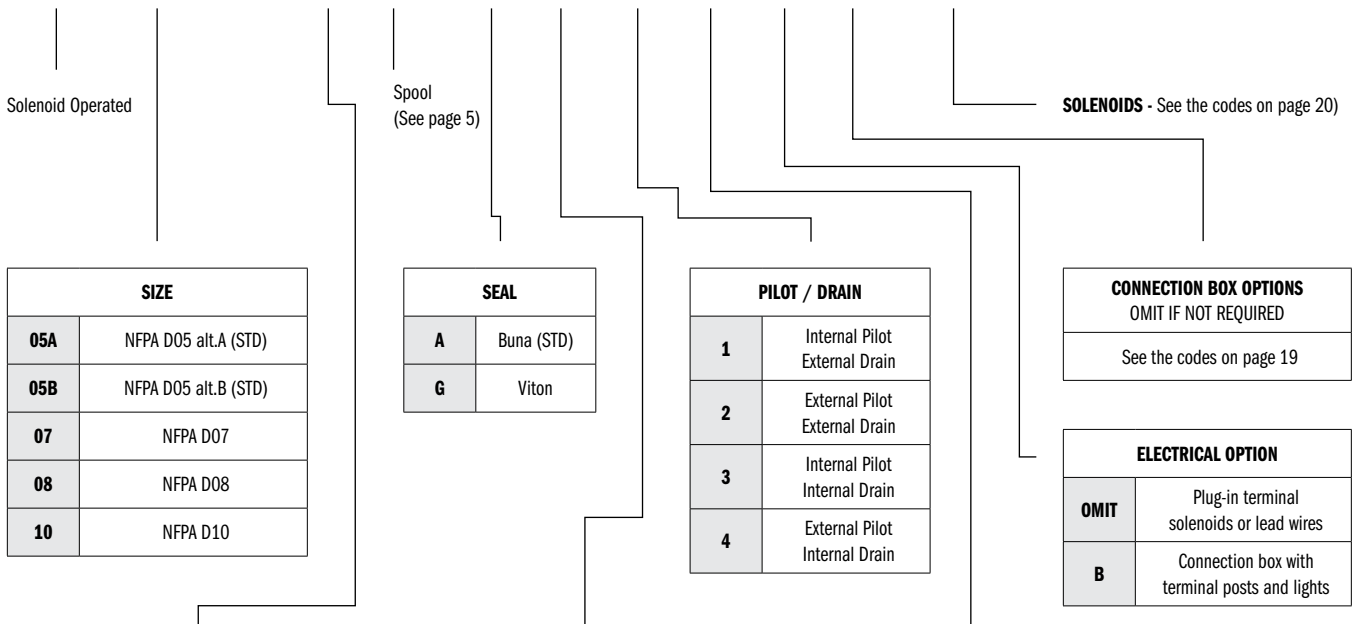

SIZE	
05A	NFPA D05 alt.A (STD)
05B	NFPA D05 alt.B (STD)
07	NFPA D07
08	NFPA D08
10	NFPA D10

SEAL	
A	Buna (STD)
G	Viton

PILOT / DRAIN	
1	Internal Pilot External Drain
2	External Pilot External Drain
3	Internal Pilot Internal Drain
4	External Pilot Internal Drain

CONNECTION BOX OPTIONS	
OMIT IF NOT REQUIRED	
See the codes on page 19	

ELECTRICAL OPTION	
OMIT	Plug-in terminal solenoids or lead wires
B	Connection box with terminal posts and lights

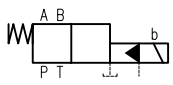
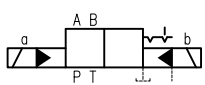
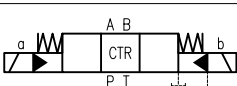
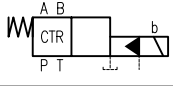
FUNCTION	
1	 Single Operator 2 Position Spring Offset
2	 Dual Operator 2 Position Detented (No Spring)
3	 Dual Operator 3 Position Spring Centered
5	 Single Operator 2 Position Spring Centered

MECHANICAL OPTIONS	
OMIT IF NOT REQUIRED	
R	Reverse Mode Sol. 'A' Supplied
JJ	Stroke Adjustment On Main Stage
JA	Stroke Adjustment On A Port End
JB	Stroke Adjustment On B Port End
KK	Adjustable Pilot Chokes
P	Restrictor Supplate On P Port Between Main And Pilot Valve
WD	Washdown

INTERNAL PILOT OPTIONS	
AVAILABLE ONLY WITH PILOT/DRAIN 1 AND 3 (OMIT IF NOT REQUIRED)	
Z	Pilot Pressure Reducer. Mandatory When Pressure Is Higher Than 3000 Psi (210 Bar). Not available for D05
C70	Check Valve On 'P' Port Cracking Pressure: 70 Psi (5 Bar). Available For D07 And D08 Sizes Only.

TYPICAL ORDERING CODE:
WITH CONNECTION BOX
VSD05AM-3A-A1B5A-60L-C
WITH PLUG-IN SOLENOID
VSD05AM-3A-A3-33L-C

The identification code for hydraulic operated valves is on page 4.

IDENTIFICATION CODE - HYDRAULIC OPERATED

VPD **M** - - **2** - _____ DESIGN LETTER

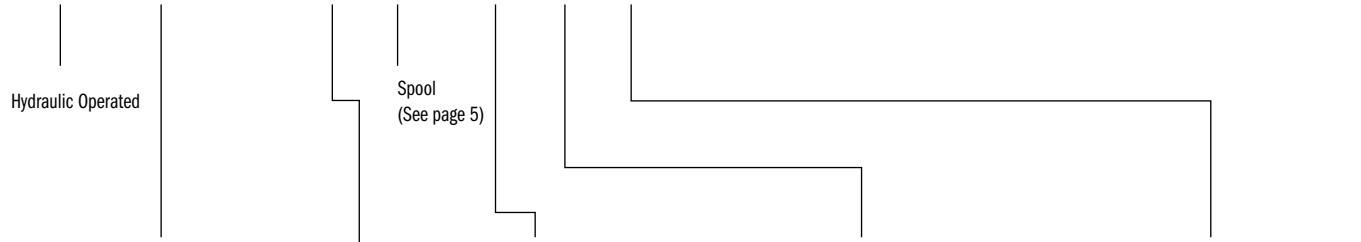

SIZE	
05A	NFPA D05 alt.A
05B	NFPA D05 alt.B
07	NFPA D07
08	NFPA D08
10	NFPA D10

SEAL	
A	Buna (STD)
G	Viton

MECHANICAL OPTIONS OMIT IF NOT REQUIRED	
R	Reverse Mode
JJ	Stroke Adjustment On Main Stage
JA	Stroke Adjustment On A Port End
JB	Stroke Adjustment On B Port End
KK	Adjustable Pilot Chokes

HYDRAULIC ACTUATION	
2	X Port Is Actuator B Y Port Is Actuator A

FUNCTION	
1	<p>Single Operator 2 Position Spring Offset</p>
3	<p>Dual Operator 3 Position Spring Centered</p>
5	<p>Single Operator 2 Position Spring Centered</p>

TYPICAL ORDERING CODE:
VPD05AM-3A-A2-A

SPOOLS FOR D05, D07 AND D10					
NAME	SYMBOL	FUNCTION	CENTER POSITION	CROSSOVER	FUNCTION MATCHING
A			All ports blocked	All ports blocked	1, 2, 3, 5
B			All ports open	All ports open	1, 2, 3, 5.
E			P & A blocked, B → T	P & A blocked, B → T or all blocked	3
F			P blocked, A → T and B → T	P blocked, A → T or B → T	3, 5
F1			P blocked, A → T and B → T restricted	P blocked, A → T or B → T restricted	3
G			P → A & B T blocked	P → A or P → B T blocked	3
K			P & B blocked, A → T.	All blocked, or P & B blocked and A → T	3
L			P → T A & B blocked	All ports open, restricted	3, 5

SPOOLS FOR D08					
NAME	SYMBOL	FUNCTION	CENTER POSITION	CROSSOVER	FUNCTION MATCHING
A			All ports blocked	All ports blocked	1, 2, 3, 5
B			All ports open	All ports open	1, 2, 3, 5
E			P & A blocked, B → T	P & A blocked, B → T or all blocked	3
F			P blocked, A → T and B → T	P blocked, A → T or B → T	3, 5
F1			P blocked, A → T and B → T restricted	P blocked, A → T or B → T restricted	3
G			P → A & B T blocked	P → A or P → B T blocked	3
K			P & B blocked, A → T	All blocked, or P & B blocked and A → T	3
L			P → T A & B blocked	All ports open, restricted	3, 5

NOTE:
Here are shown only the most frequently used spools. Consult with Continental Hydraulics for special version availability.

PERFORMANCE CURVES FOR VSD05*M - VPD05*M

FLOW GAIN

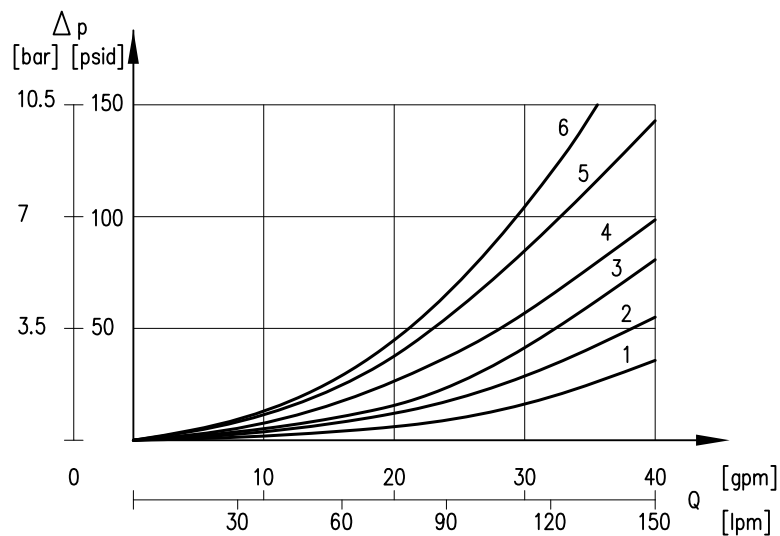

SPOOL	FLOW CURVE NUMBER									
	SHIFTED				CENTER					
	P→A	P→B	A→T	B→T	P→A	P→B	A→T	B→T	P→T	
1A	5	5	2	3	-	-	-	-	-	
2A	5	5	2	3	-	-	-	-	-	
3A, 5A	5	5	1	3	-	-	-	-	-	
3B, 5B	4	4	1	2	-	-	-	-	6	
3E, 5E	5	5	1	2	-	-	-	5	-	
3F, 5F	5	5	1	2	-	-	5	5	-	
3F1, 5F1	5	5	1	1	-	-	-	-	-	
3G, 5G	4	4	3	3	5	5	-	-	-	
3K, 5K	5	5	3	3	-	-	5	-	-	
3L, 5L	6	6	1	1	-	-	-	-	6	

NOTE:

Curves obtained with mineral oil with viscosity of 170 SUS (36 cSt) at 122°F (50°C).

RESPONSE TIME

TIMES [ms]	ENERGIZING	DE-ENERGIZING
AC	25 MS	25 MS
DC	50 MS	50 MS

NOTE:

The values indicated refer to a solenoid valve working with 1450 psi (100 bar) pilot pressure, with mineral oil at 120°F (50°C) and viscosity of 165 SUS (36cSt). The energizing and de-energizing times are obtained at the point pressure changes in the work ports.

PERFORMANCE CURVES FOR VSD07M - VPD07M

FLOW GAIN

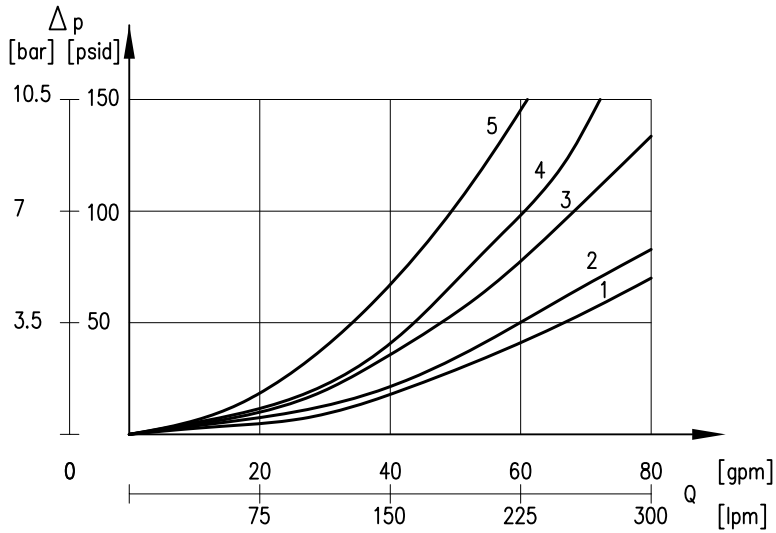

SPOOL	FLOW CURVE NUMBER									
	SHIFTED				CENTER					
	P→A	P→B	A→T	B→T	P→A	P→B	A→T	B→T	P→T	
1A, 1B, 2A, 3A, 5A	1	1	3	4	-	-	-	-	-	
3B, 5B	1	1	4	4	-	-	-	-	2	
3E	1	1	3	4	-	-	-	4	-	
3F, 5F	1	1	4	4	-	-	4	4	-	
3F1, 5F1	1	1	3	4	-	-	-	-	-	
3G, 5G	1	1	3	4	-	-	-	-	-	
3K, 5K	1	1	3	4	-	-	4	-	-	
3L, 5L	2	2	4	5	-	-	-	-	4	

NOTE:

Curves obtained with mineral oil with viscosity of 170 SUS (36 cSt) at 122°F (50°C).

RESPONSE TIME

TIMES [ms]	ENERGIZING	DE-ENERGIZING
AC	30 MS	30 MS
DC	60 MS	45 MS

NOTE:

The values indicated refer to a solenoid valve working with 1450 psi (100 bar) pilot pressure, with mineral oil at 120°F (50°C) and viscosity of 165 SUS (36cSt). The energizing and de-energizing times are obtained at the point pressure changes in the work ports.

PERFORMANCE CURVES FOR VSD08M - VPD08M

FLOW GAIN

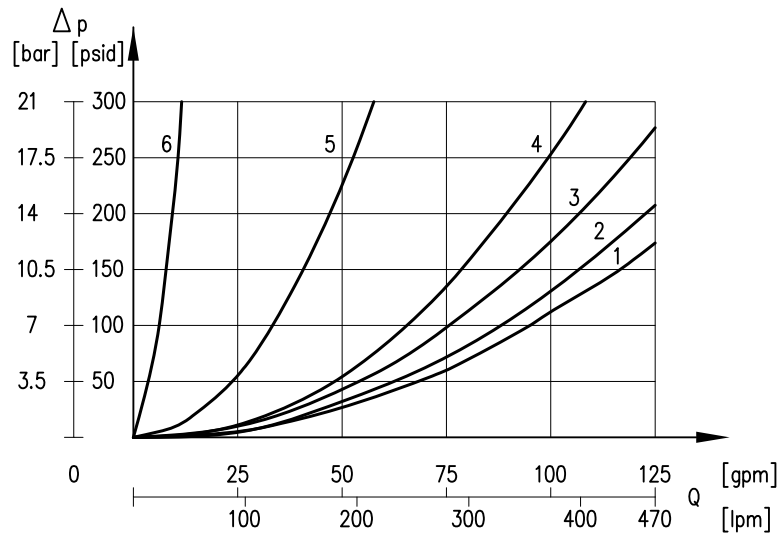

SPOOL	FLOW CURVE NUMBER								
	SHIFTED				CENTER				
	P→A	P→B	A→T	B→T	P→A	P→B	A→T	B→T	P→T
1A, 2A, 3A, 5A	1	1	2	2	-	-	-	-	-
1B, 3B, 5B	1	1	2	2	-	-	-	-	3
3F, 5F	1	1	2	2	-	-	3	3	-
3F1	1	1	2	2	-	-	6	6	-
3G	1	1	2	2	4	4	-	-	-
3K	1	1	2	2	-	-	5	-	-
3L, 5L	3	3	3	3	-	-	-	-	4

NOTE:

Curves obtained with mineral oil with viscosity of 170 SUS (36 cSt) at 122°F (50°C).

RESPONSE TIME

TIMES [ms]	ENERGIZING	DE-ENERGIZING
AC	30 MS	60 MS
DC	60 MS	80 MS

NOTE:

The values indicated refer to a solenoid valve working with 1450 psi (100 bar) pilot pressure, with mineral oil at 120°F (50°C) and viscosity of 165 SUS (36cSt). The energizing and de-energizing times are obtained at the point pressure changes in the work ports.

PERFORMANCE CURVES FOR VSD10M - VPD10M

FLOW GAIN

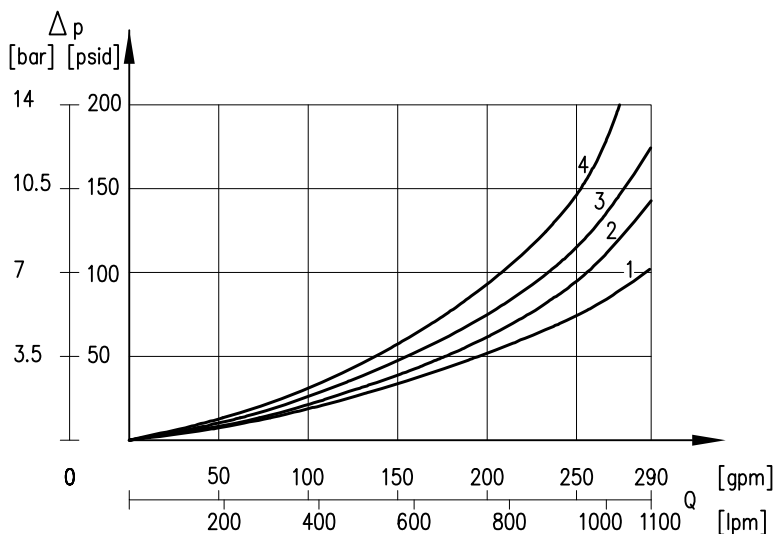

SPOOL	FLOW CURVE NUMBER									
	SHIFTED				CENTER					
	P→A	P→B	A→T	B→T	P→A	P→B	A→T	B→T	P→T	
1A, 1B, 2A, 3A, 5A	1	1	1	1	-	-	-	-	-	
3B, 5B	2	2	2	2	-	-	-	-	3	
3F, 5F	1	1	4	4	-	-	4	4	-	
3L, 5L	2	2	2	2	-	-	-	-	4	

NOTE:

Curves obtained with mineral oil with viscosity of 170 SUS (36 cSt) at 122°F (50°C) and pilot valve at 24V AC.

RESPONSE TIME

TIMES [ms]	ENERGIZING	DE-ENERGIZING
AC	65 MS	65 MS
DC	100 MS	65 MS

NOTE:

The values indicated refer to a solenoid valve working with 1450 psi (100 bar) pilot pressure, with mineral oil at 120°F (50°C) and viscosity of 165 SUS (36cSt). The energizing and de-energizing times are obtained at the point pressure changes in the work ports.

MECHANICAL OPTIONS

STROKE ADJUSTMENT (JJ)

This modification controls the flow of oil through the valve by limiting spool movement. It is used in hydraulic systems to govern the speed of system components.

This solution allows control of the flow rate from the pump to the actuator and from the actuator to the outlet, obtaining a double adjustable control on the actuator.

It is possible to order the valve with the stroke adj. on one side only. To request these options add the letters JA or JB in the Mechanical options box in the identification code.

The stroke adjustment kit is also available as an accessory. It includes 1 stroke assembly (one end only) and related seals. This kit is suitable even for the hydraulic operated version.

DIMENSION	VSD05*M	VSD07M	VSD08M	VSD10M
A	280 [11]	320 [12.6]	417 [16.40]	520 [20.5]
B	80 [3.15]	69 [2.72]	89 [3.50]	90 [3.54]

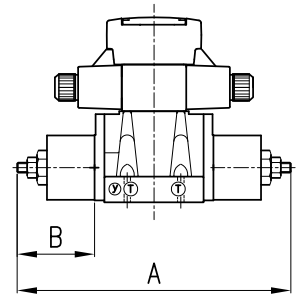

USE THE CODE BELOW TO ORDER STROKE ADJUSTMENT KIT.

VALVE SERIES	SEAL MATERIAL	ORDERING NUMBER
VSD05*M	Buna N	VMA-3A1
	Viton	VMA-3A2
VSD07M	Buna N	VMA-4A1
	Viton	VMA-4A2
VSD08M	Buna N	VMA-5A1
	Viton	VMA-5A2
VSD10M	Buna N	VMA-7A1
	Viton	VMA-7A2

ADJUSTABLE PILOT CHOKES (KK)

Hydraulic shock may occur when stopping or reversing flow. This can be reduced and controlled by lowering the spool shift velocity. The chokes operate by metering out (returning) on all 2 position valves, and when going to center position on 3-position valves.

To request this option add the letters 'KK' in the mechanical options box, in the identification.

Consult with Continental Hydraulics for other metering configurations.

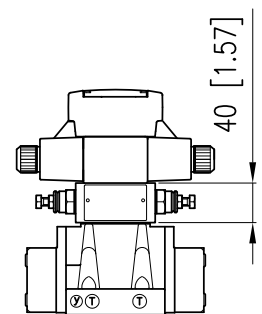
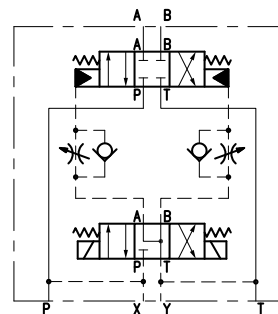

RESTRICTOR SUBPLATE (P)

It is possible to introduce a subplate with a restrictor of $\varnothing 0.8$ mm [0.03 in] on line P between the pilot solenoid valve and the main distributor with the purpose of increasing the switching time.

This part is 10 mm [0.39 in] tall.

To request this option add the letter 'P' in the mechanical options box, in the identification code.

PILOT AND DRAIN CONFIGURATION

The VPD*M valves are available with external pilot and drain only. The VSD*M valves are available with four pilot/drain configurations: internal/internal, internal/external, external/internal and external/external.

When internal pilot and/or drain are used, the corresponding 'x' and 'y' ports in the manifold must be plugged. Pilot pressure must be at least 70 psi (5 bar) greater than the pressure in the 'T' line.

It may be desirable to use external pilot when system pressure is subject to wide fluctuations. It is required to use external pilot or internal pilot with a pressure reducing valve when system pressure exceeds 3000 psi (210 bar) for the VSD05*M, VSD07M and VSD10M.

An external drain must be used when an open center (B) or a tandem center (L) spool is used, and is also recommended when using pilot checks. The version with external drain allows for higher tank line pressure in series circuits.

CODE	DESIGN	VSD05*M, VSD07M, VSD10M		VSD08M	
		Pilot (X)	Drain (Y)	Pilot (X) (W)	Drain (Y)
1	Internal Pilot / External Drain	□	■	■ ■	■
2	External Pilot / External Drain	■	■	■ □	■
3	Internal Pilot / Internal Drain	□	□	■ ■	□
4	External Pilot / Internal Drain	■	□	■ □	□

■ Plugged □ Unplugged ■ Restricted

PLUG MOUNTING

VSD05M

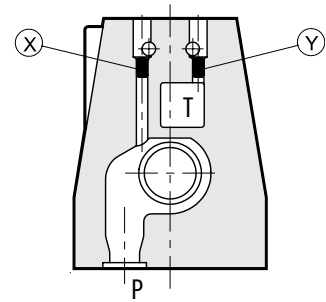

VSD07M

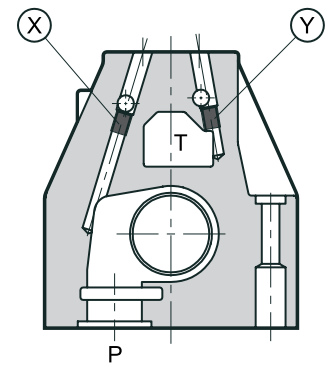

VSD08M

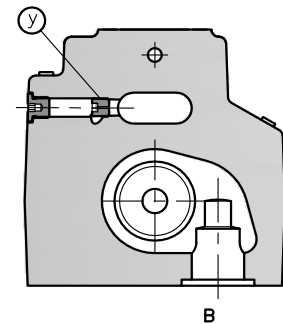

VSD10M

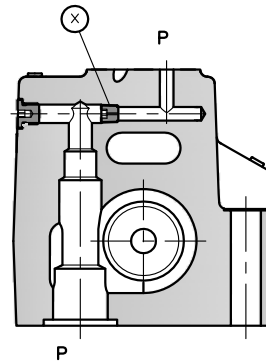
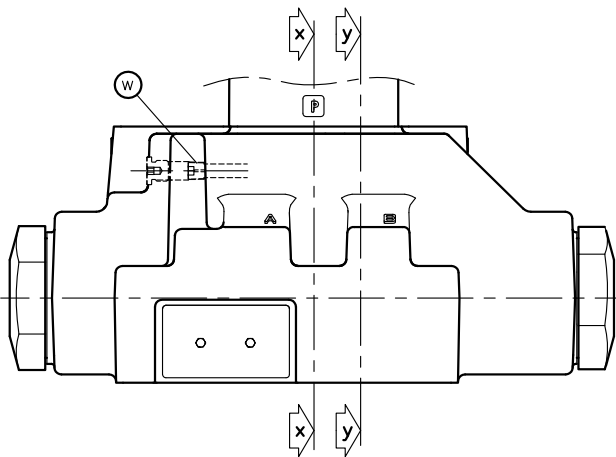
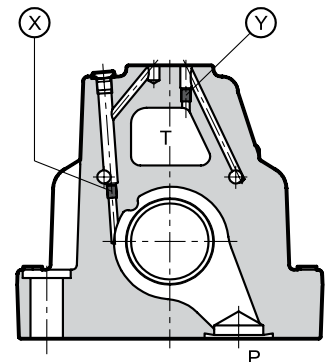

PLUG SIZE:

VSD05*M	M5x6 mm
VSD07M	M6x8 mm
VSD10M	M6x8 mm
VSD08M	1/16" NPT Pipe Plug 1/16" NPT Pipe Plug with Ø 0.070 (1.78MM) Orifice

INTERNAL PILOT OPTIONS

PRESSURE REDUCING (Z)

THE PRESSURE REDUCING MODULE IS TO PROTECT THE VALVE FROM PILOT PRESSURES EXCEEDING 3000 PSI (210 BAR).

When the system pressure exceeds 3000 psi it is mandatory the use of an external pilot, or optional Z for internally piloted versions.

The pressure reducer is fixed at 430 psi (30 bar). This device is not available for the VSD05*M.

To request this option add the letter 'Z' in the internal pilot options box, in the identification code.

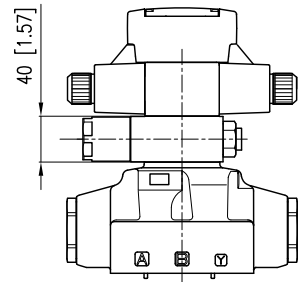

BACK PRESSURE VALVE (C70)

The back pressure valve is for valves with internal pilot and B or L spool types where system pressure may drop below the 70 psi (5 bar) required for pilot operation.

This device is available only for VSD07M and VSD08M.

NOTE: The back pressure valve can't be used as check because it doesn't assure the seal.

To request this option add the letters 'C70' in the internal pilot options box, in the identification code.

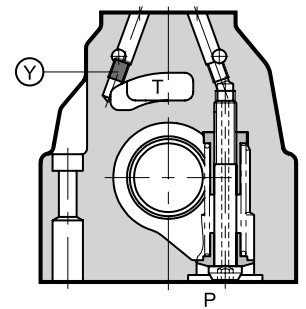

The backpressure valve is also available as a field conversion kit and can be easily mounted in the P port of the main control valve.

The kit includes 1 check assembly and related seals.

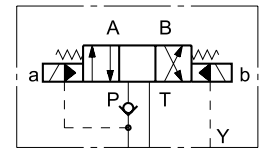

USE THE CODE BELOW TO ORDER THE KIT.

VALVE SERIES	SEAL MATERIAL	ORDERING NUMBER
VSD07M	Buna N	VMA-4F1-A
	Viton	VMA-4F2-A
VSD08M	Buna N	VMA-5F1-A
	Viton	VMA-5F2-A

OVERALL AND MOUNTING DIMENSIONS FOR VSD05*M

VSD05*M

Dimensions in mm [IN]

NOTES:

1. Drawings and dimensions refer to the AC version of pilot valve, with conduit box and 5A receptacle option on A port end.

THREAD OF MOUNTING HOLES

1/4 - 20 UNC -2B x 0.60

FASTENING

4 bolts 1/4 - 20 UNC-2B x 1 1/2
Grade 8 or stronger

TIGHTENING TORQUE

6 lbf-ft (8 Nm)

SEALING RINGS

5 O-rings AS568-014 90 shore A
2 O-rings AS568-012 90 shore A

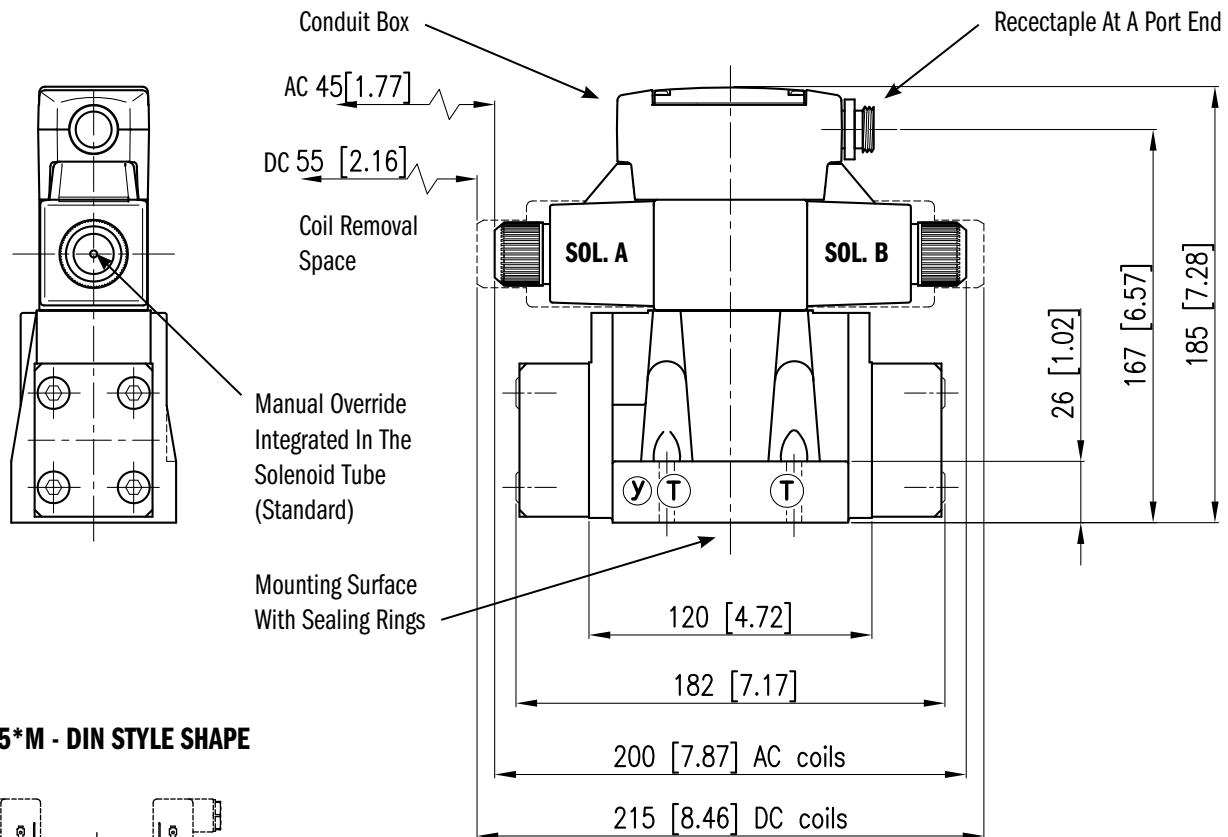
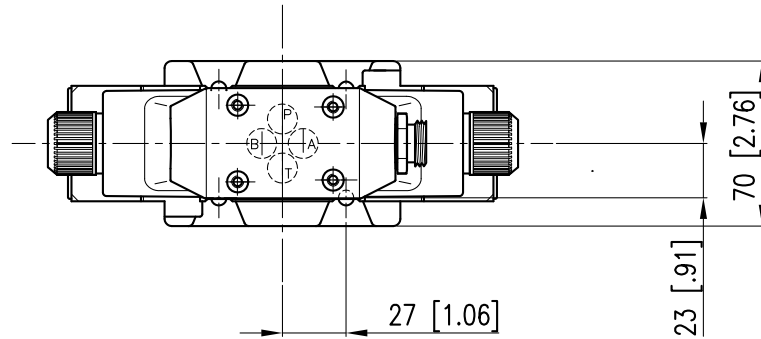

VSD05*M - DIN STYLE SHAPE

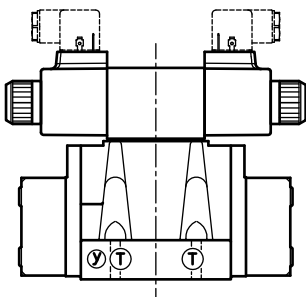

VSD *M-VPD *M - PILOT OPERATED DIRECTIONAL VALVES

OVERALL AND MOUNTING DIMENSIONS FOR VSD07M

VSD07M

Dimensions in mm [IN]

NOTES:

1. Drawings and dimensions refer to the AC version of pilot valve, with conduit box and 5A receptacle option on A port end.

THREAD OF MOUNTING HOLE

1/4 - 20 UNC - 2B x 0.5

3/8 - 16 UNC - 2B x 0.9

FASTENING

2 bolts 1/4-20 UNC-2B x 2

Grade 8 or stronger

4 bolts 3/8-16 UNC-2B x 2 1/2

Grade 8 or stronger

TIGHTENING TORQUE

1/4 - 20 UNC - 2B: 6 lbf-ft (8 Nm)

3/8 - 16 UNC - 2B: 30 lbf-ft (40 Nm)

SEALING RINGS

4 O-rings 22.22 mm ID x 2.62 mm CS90 shore 90A

2 O-rings AS568-013 90 shore A

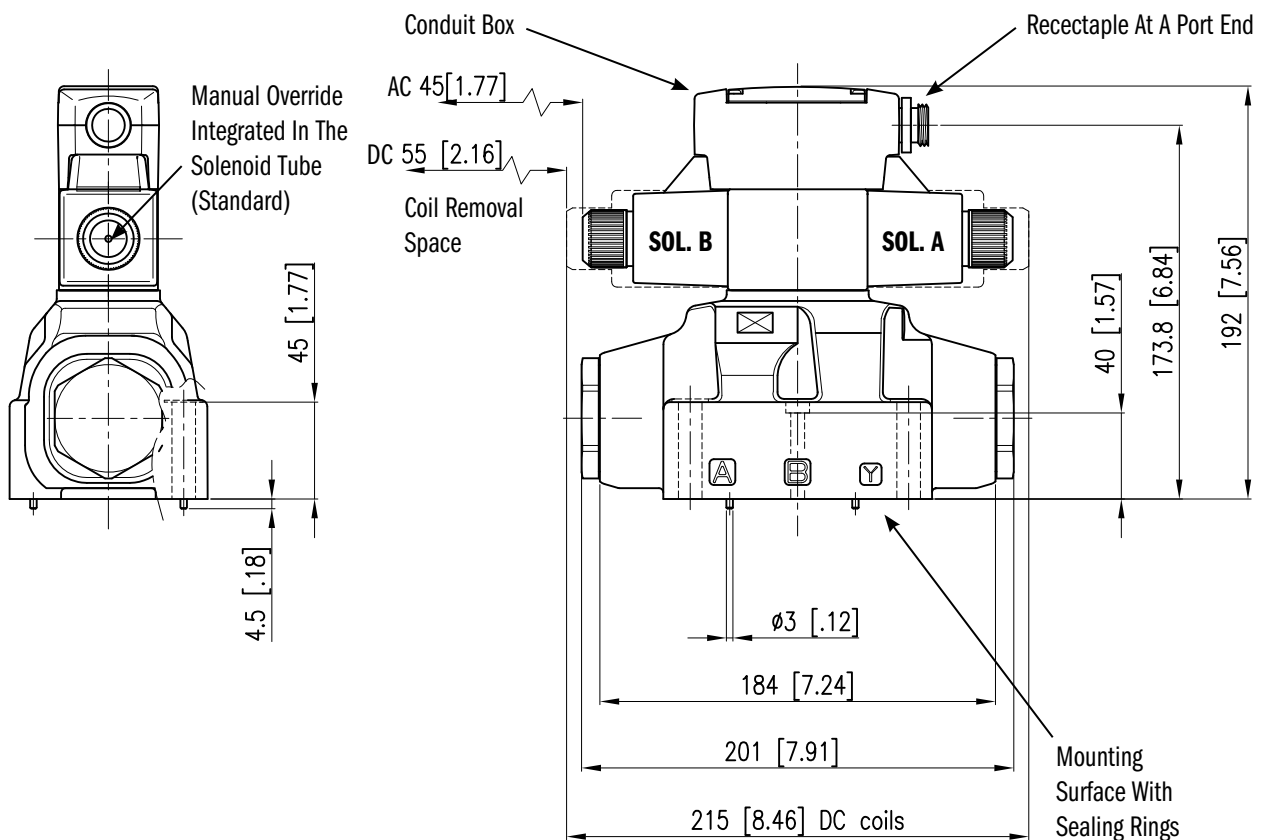
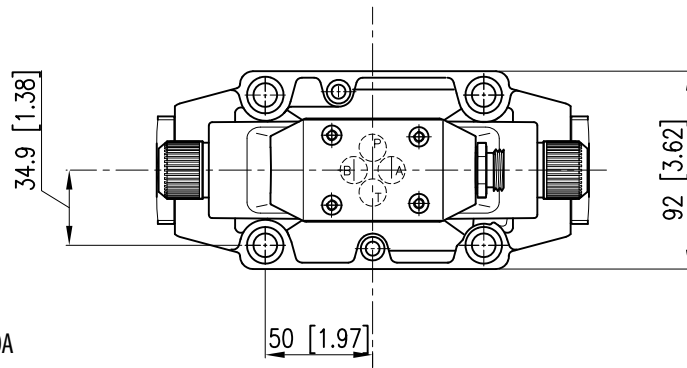

OVERALL AND MOUNTING DIMENSIONS FOR VSD08M

VSD08M

Dimensions in mm [IN]

NOTES:

1. Drawings and dimensions refer to the AC version of pilot valve, with conduit box and 5A receptacle option on A port end.
2. On this size A and/or B operator reverse sides.

THREAD OF MOUNTING HOLES

1/2 - 13 UNC x 0.7

FASTENING

6 bolts 1/2 - 13 UNC x 2 1/2
Grade 8 or stronger

TIGHTENING TORQUE

90 to 100 lbf-ft (122 to 136 Nm)

SEALING RINGS

4 O-ring AS568 -215 90 shore A
2 O-ring AS568 -210 90 shore A

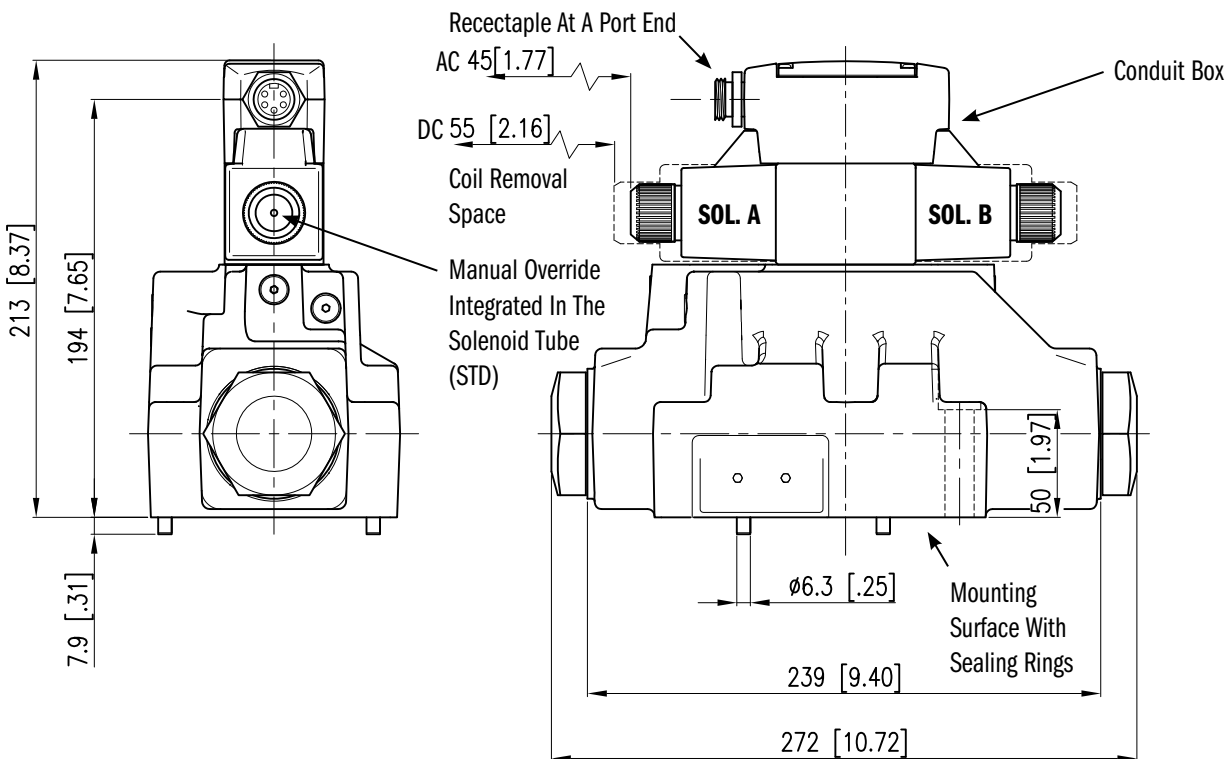

VSD *M-VPD *M - PILOT OPERATED DIRECTIONAL VALVES

OVERALL AND MOUNTING DIMENSIONS FOR VSD10M

VSD10M

Dimensions in mm [IN]

NOTES:

1. Drawings and dimensions refer to the AC version of pilot valve, with conduit box and 5A receptacle option on A port end.
2. On this size A and/or B operator reverse sides.

THREAD OF MOUNTING HOLES

3/4 - 10 UNC - 2B x 1.3

FASTENING

6 bolts 3/4 - 10 UNC - 2B x 2 3/4
Grade 8 or stronger or high strength

TIGHTENING TORQUE

240 lbf-ft (325 Nm)
415 lbf-ft (565 Nm) high strength

SEALING RINGS

4 O-Ring AS568-222 90 shore A
2 O-Ring AS568-117 90 shore A

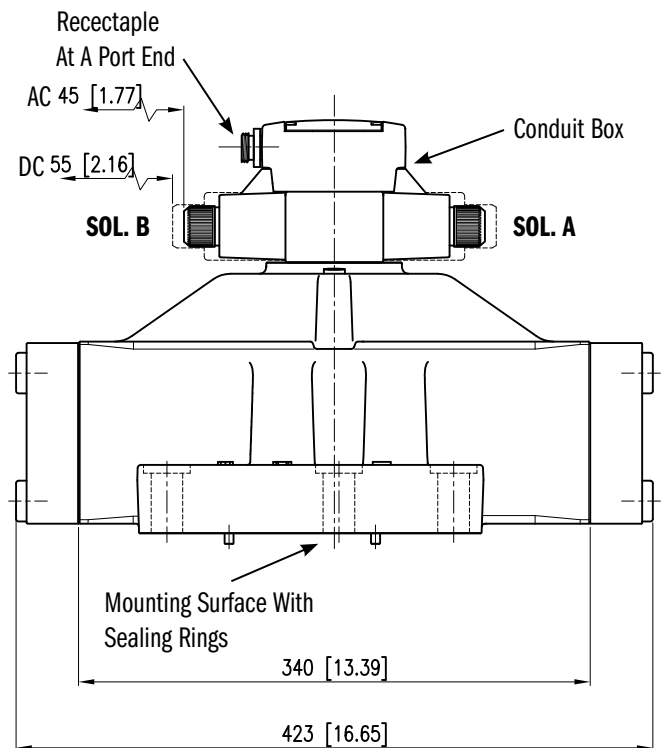
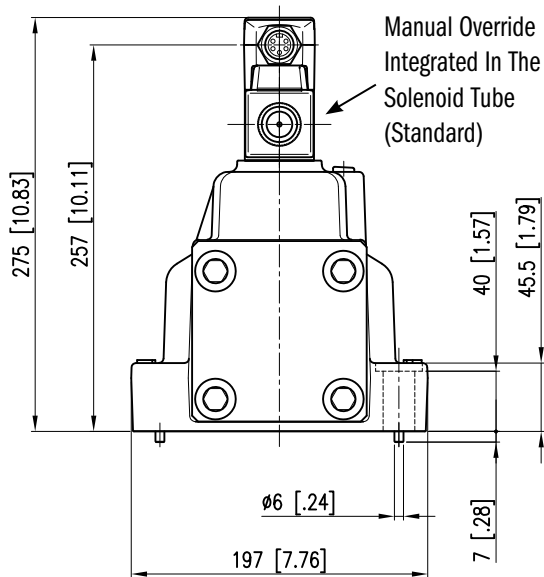
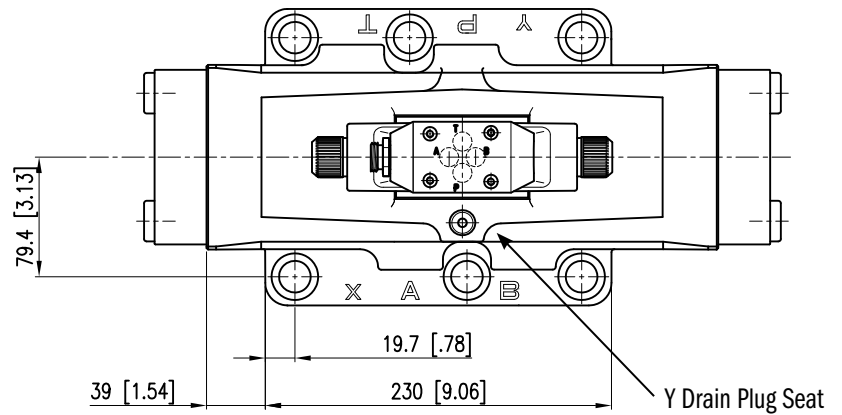

OVERALL AND MOUNTING DIMENSIONS VPD05*M

VPD05*M

Dimensions in mm [IN]

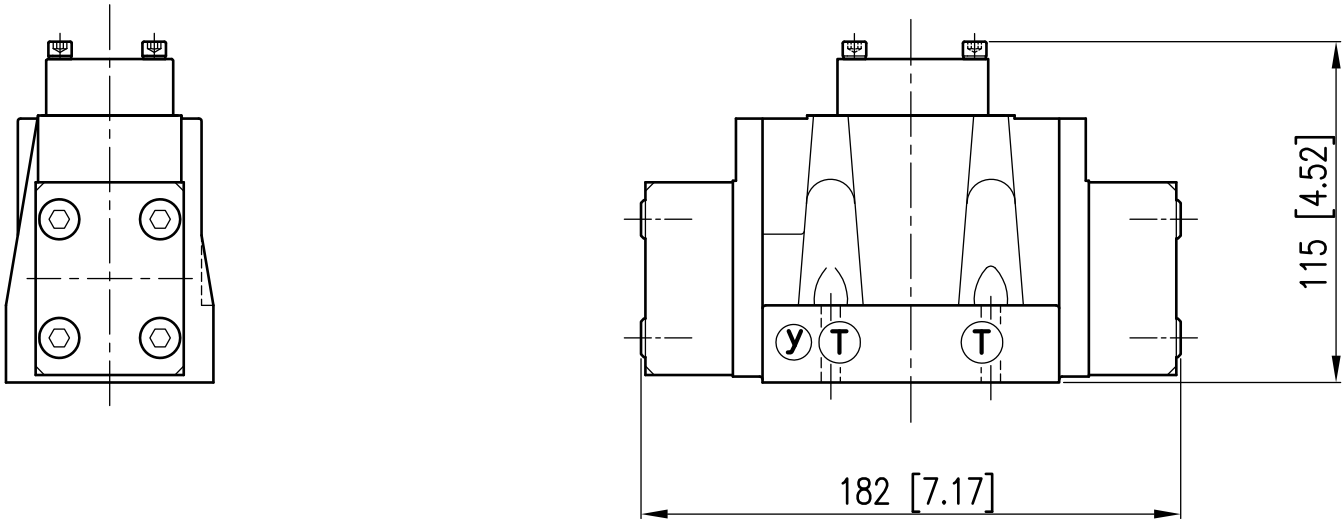

NOTE:

For missing dimensions, sealing rings and bolts information, please refer to the solenoid operated version drawings.

OVERALL AND MOUNTING DIMENSIONS VPD07M

VPD07M

Dimensions in mm [IN]

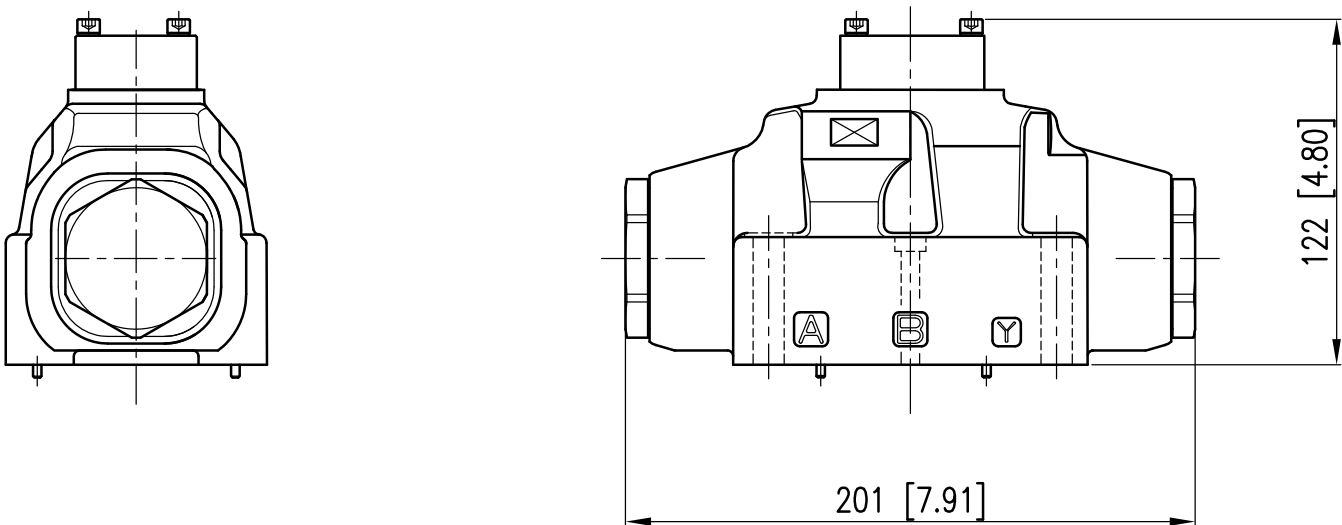

OVERALL AND MOUNTING DIMENSIONS VPD08M

VPD08M

Dimensions in mm [IN]

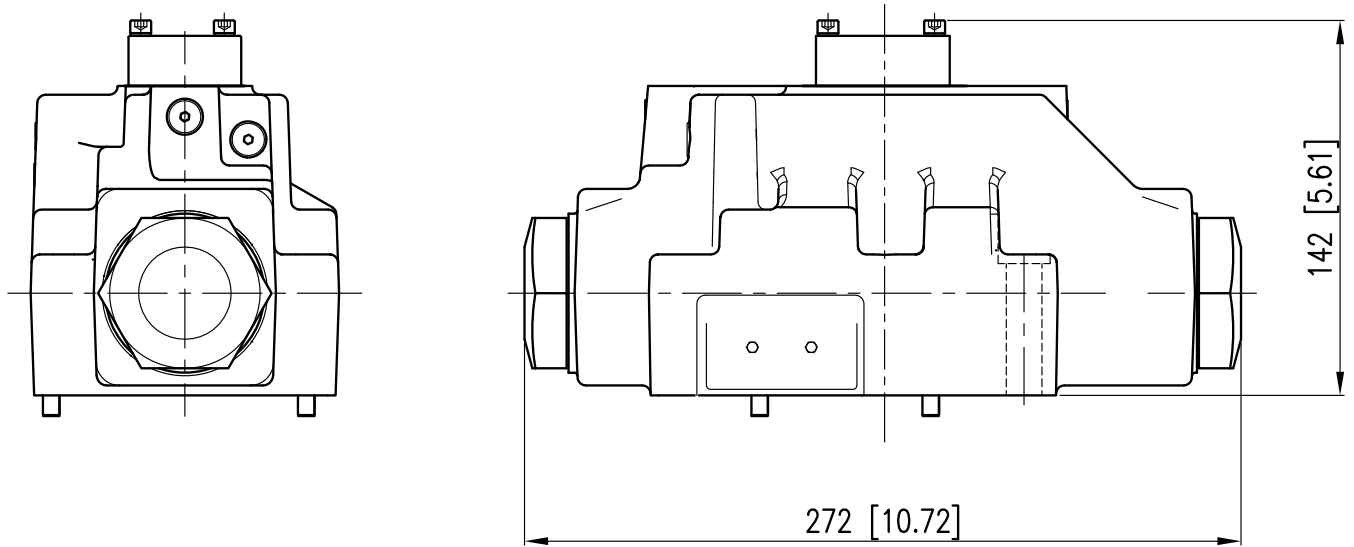

NOTE:

For missing dimensions, sealing rings and bolts information, please refer to the solenoid operated version drawings.

OVERALL AND MOUNTING DIMENSIONS VPD10M

VPD10M

Dimensions in mm [IN]

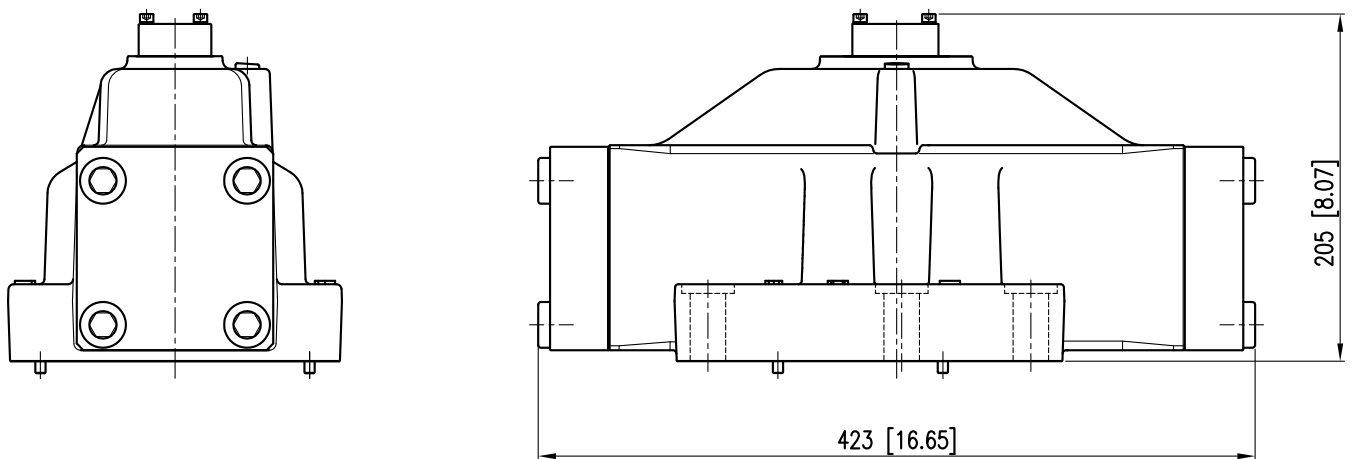

ELECTRICAL CHARACTERISTICS

Valves are available with an electrical connection box or with DIN 43650 solenoids in both AC and DC voltages. Deutsch DT04 or lead wires are also available in DC voltages only.

CONNECTION BOX OPTIONS

To simplify the connections and prevent wiring mistakes, we offer the option with connection boxes with quick connect pin receptacles, already wired.

Valves are available with receptacles on solenoid side 'A' or 'B' and several connector styles.

Below are the codes to be included in the box 'option' of the ordering code, depending on the version you choose.

Wiring diagrams at right show the standard connections for 3-pin, 4-pin and 5-pin connectors. The commercially available mating "female" connector are not included.

CODE	PIN	SHAPE	PORT END	NOTES
5A	5	Male Mini	A	Single and Dual Solenoid
5H	5		B	
3A	3	Male Mini	A	Single Solenoid Only
3H	3		B	
4A	4	Male Micro	A	For DC Current Only. Different Wiring. See Schematics.
D4A	4		A	
4	4		B	
D4	4		B	

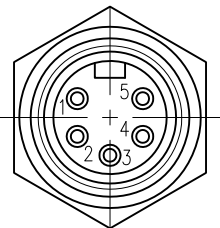

5 PIN RECEPTACLE

Male mini receptacles conform to NFPA/T3.5.29 R1 - 2007 used with single or double solenoid valve.

26 mm [1"] Wrench

1	Lead to Solenoid B
2	Lead to Solenoid A
3	Ground Lead (Green)
4	Lead to Solenoid A
5	Lead to Solenoid B

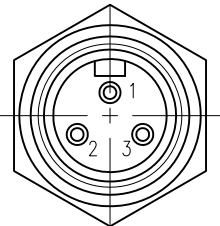

3 PIN RECEPTACLE

Male mini receptacles conform to NFPA/T3.5.29 R1 - 2007 used with single solenoid valve.

26 mm [1"] Wrench

1	Ground Lead (Green)
2	Lead to Solenoid
3	Lead to Solenoid

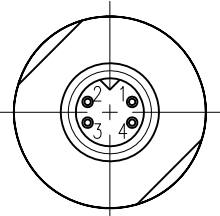

4 PIN RECEPTACLE

Male micro receptacles (M12x1 thread) used with DC valve only.

23 mm [7/8] Wrench

4A & 4		
1	Brown	Lead to Solenoid A
2	White	No Connection
3	Blue	Common Lead to Sol. A & B
4	Black	Lead to Solenoid B

D4A & D4		
1	Brown	No Connection
2	White	Lead to Solenoid A
3	Blue	Common Lead to Sol. A & B
4	Black	Lead to Solenoid B

SOLENOIDS

Listed below the types of solenoids available and the numbers to be added in the solenoid box on page 3.

PLUG-IN TERMINAL SOLENOID

DIN 43650

This solenoid has three terminal posts. Use bi-polar connectors that meet ISO 4400 / DIN 43650 (EN 175301-803). Protection against atmospheric agent: IP 65

LEAD WIRES

6 inch length, protection against atmospheric agent: IP 67

DEUTSCH DT04 MALE

Protection against atmospheric agent: IP 69
Connectors must be ordered separately.

DEUTSCH DT04 MALE

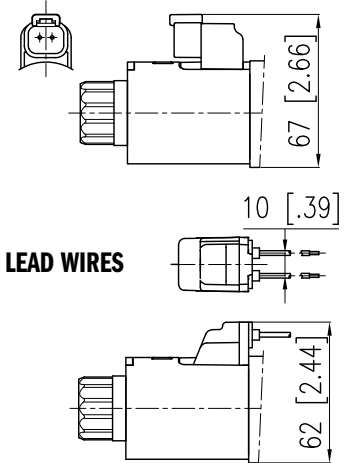

CONNECTION BOX SOLENOIDS

This is a two pin solenoid which connects to the circuit board. Wiring is done on the terminal strip inside the box.

DIN CONNECTION CODE	LEAD WIRE CONNECTION CODE	DEUTSCH DT04 CONNECTION CODE	BOX CONNECTION CODE	VOLTAGE & FREQ. [VOLT - HERTZ]	VOLTAGE LIMITS [MIN - MAX]	RESISTANCE ±10% [OHM]	INRUSH CURRENT [A]	HOLDING CURRENT [A]	HOLDING POWER [W]
33	Not Available	Not Available	60	120 - 60 110 - 50	108 - 126 99 - 116	35.7	1.35 1.41	0.46 0.53	22 23
34	Not Available	Not Available	61	240 - 60 220 - 50	216 - 252 198 - 231	146.4	0.61 0.71	0.23 0.26	22 23
Not Available	Not Available	Not Available	68	120 - 60 110 - 50	108 - 132 99 - 121	75.8	0.72 0.74	0.22 0.24	10 10
42	24K4	24K7	70	24 V DC	21 - 26	19.2	1.25	1.25	30
44	12K4	12K7	75	12 V DC	10 - 13	4.8	2.5	2.5	30

WASHDOWN OPTION (CODE WD)

The wash-down option with the electrical box is designed for an IP65 rating. This option uses a special cover without the mounting bolt access holes and uses silicone sealant to help seal between the coil and core tube.

The DIN, Deutsch and lead wire coils versions of the wash-down option uses silicone sealant to help seal between the coil and core tube.

MOUNTING SURFACES

ALL THE MOUNTING SURFACES REFER TO NFPA T3.5.1 R2-2002 AND ISO 4401:2005 STANDARDS.

The mounting surface standards recommends metric coarse threads. However, subplates are commercially available with UNC threads. Select a bolt size that matches the threads in the mounting surface.

Dimensional tolerances are ± 0.1 mm (0.004") for bolt and pin location; ± 0.2 mm (0.008") for the other quotes.

The minimum depth of the blind hole G where required is 8 mm (0.31 in).

D05 - ALTERNATIVE A

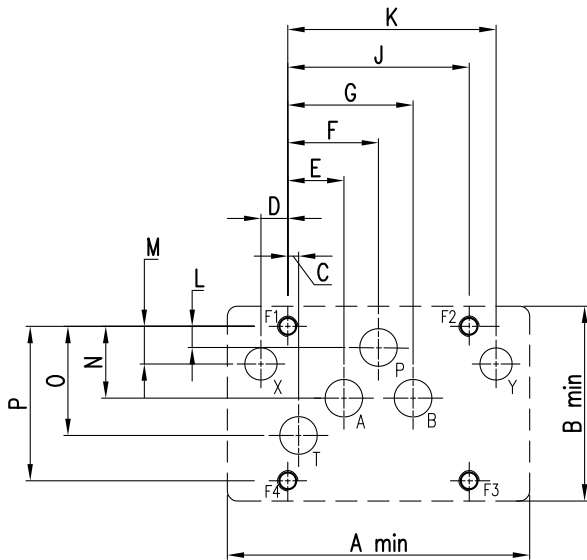

D05 - ALTERNATIVE B

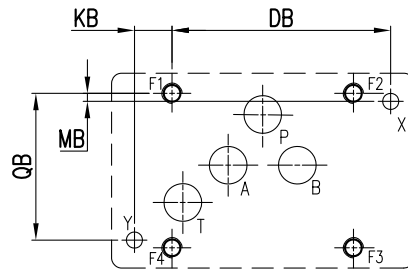

PORT FUNCTION:

P = PRESSURE PORT
T = TANK PORT

A = FIRST CYLINDER PORT
X = PILOT PORT

B = SECOND CYLINDER PORT
Y = DRAIN PORT

	MM	INCH
P, A, B, T MAX	∅ 11.2	∅ 0.44
X, Y ALT. A	∅ 6.3	∅ 0.25
X, Y ALT. B	∅ 4.8	∅ 0.19
MOUNTING BOLT THREAD SIZE	M6	1/4-20 UNC

	MM	INCH
A	90	3.54
B	58	2.28
C	3.2	0.126
D	8	0.31
E	16.7	0.66
F	27	1.06
G	37.3	1.47

	MM	INCH
J	54	2.125
K	62	2.44
L	6.3	0.25
M	11.2	0.44
N	21.4	0.84
O	32.5	1.28
P	46	1.82

	MM	INCH
DB	65.1	2.563
KB	11.2	0.44
MB	2.4	0.09
QB	43.7	1.72

NOTES:

NFPA D05 and ISO 4401-05 indicates different diameters for X and Y holes:

NFPA: ∅ 9.6 max in D05 alt A
∅ 4.8 max in D05 alt B

ISO: ∅ 6.3 max both

D07

	MM	INCH
P, A, B, T MAX	∅ 17.5	∅ 0.69
X, Y MAX	∅ 6.3	∅ 0.25
G MAX	∅ 4	∅ 0.16
MOUNTING BOLT THREAD SIZE F1 - F4	M10	3/8-16 UNC
MOUNTING BOLT THREAD SIZE F5 - F6	M6	1/4-20 UNC

	MM	INCH
A	122	4.8
B	91	3.58
C	18.3	0.72
D	34.1	1.34
E	50	1.97
F	65.9	2.60
G	76.6	3.016
H	88.1	3.47

	MM	INCH
J	101.6	4.0
K	1.6	0.063
L	14.3	0.56
M	15.9	0.626
N	55.6	2.19
O	57.2	2.25
P	69.9	2.75
Q	71.5	2.815

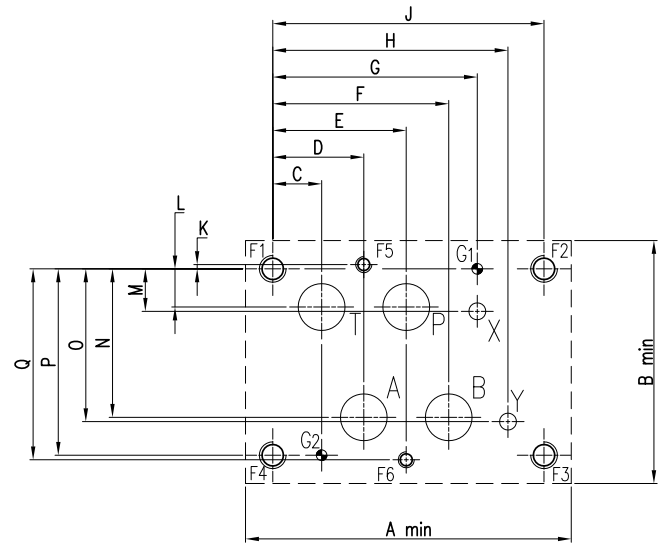

D08

	MM	INCH
P, A, B, T MAX	∅ 25	∅ 0.98
X, Y MAX	∅ 11.2	∅ 0.44
G MAX	∅ 7.5	∅ 0.30
MOUNTING BOLT THREAD SIZE	M12	1/2-13 UNC

	MM	INCH
A	154	6.0
B	116	4.57
C	17.5	0.69
D	29.4	1.157
E	53.2	2.09
F	77	3.03
G	94.5	3.719
H	100.8	3.97

	MM	INCH
J	112.7	4.44
K	130.2	5.125
L	4.80	0.187
M	17.5	0.69
N	19	0.75
O	73	2.874
P	74.6	2.93
Q	92.1	3.625

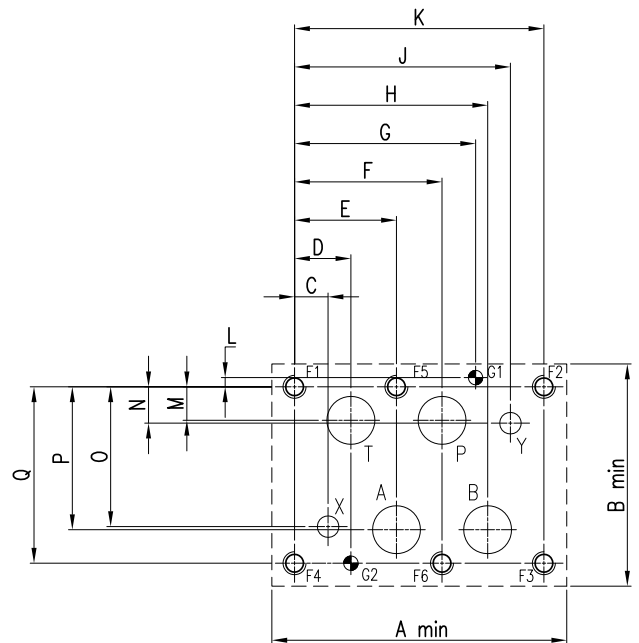

D10

	MM	INCH
P, A, B, T MAX	∅ 32	∅ 1.25
X, Y MAX	∅ 11.2	∅ .44
G MAX	∅ 7.5	∅ .30
MOUNTING BOLT THREAD SIZE	M20	¾ - 10 UNC

	MM	INCH
A	230	9.06
B	199	7.83
C	41.3	1.63
D	76.2	3.0
E	82.5	3.25
F	114.3	4.5
G	138.6	5.457
H	147.6	5.81

	MM	INCH
J	168.3	6.63
K	190.5	7.5
L	35	1.38
M	44.5	1.75
N	123.8	4.87
O	130.2	5.13
P	158.8	6.25

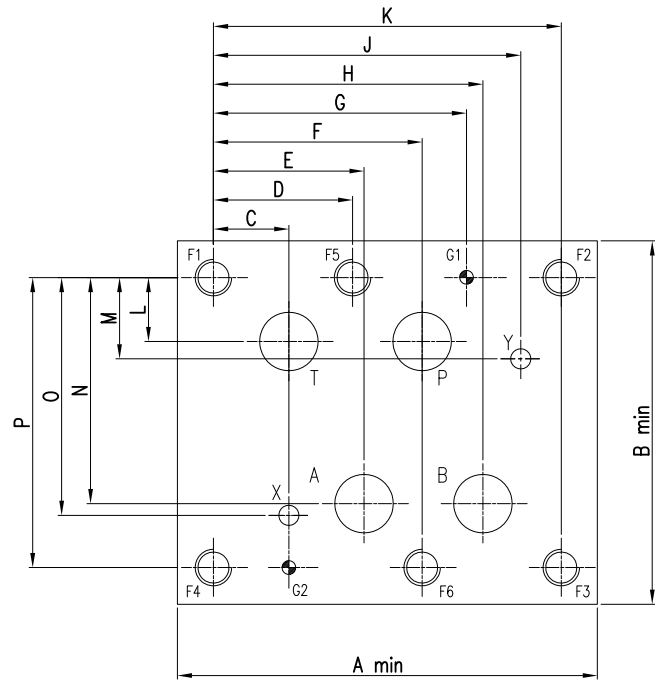

VSD *M-VPD *M - PILOT OPERATED DIRECTIONAL VALVES

APPLICATION DATA

FLUIDS

All pressure drops shown on these data pages are based on 170 SUS fluid viscosity and 0.87 specific gravity. For any other specific gravity (G1) the pressure drop (ΔP) will be approx. $\Delta P1 = \Delta P (G1/G)$. See the chart for other viscosities.

FLUID VISCOSITIES	Cst	10	14.5	32	36	43	54	65	76	86	108	216	324	400
	SUS	60	75	150	170	200	250	300	350	400	500	1000	1500	1900
MULTIPLIER		0.77	0.81	0.97	1.00	1.04	1.10	1.15	1.20	1.24	1.31	1.56	1.72	1.83

Use mineral oil-based hydraulic fluids HL or HM type, according to ISO 6743-4. For these fluids, use NBR seals. For fluids HFDR type (phosphate esters) use FPM seals (code G). For the use of other kinds of fluid such as HFA, HFB, HFC, please consult our technical department.

Using fluids at temperatures higher than 180 degrees F causes the accelerated degradation of seals as well as degradation of the fluids physical and chemical properties.

From a safety standpoint, temperatures above 130 degrees F are not recommended.

RANGE TEMPERATURES:	Ambient	-4 to +130 °F	-20 to +54 °C
	Fluid	-4 to +180 °F	-20 to +82 °C
FLUID VISCOSITY	Range	60 -1900 SUS	10 - 400 cSt
	Recommended	120 SUS	25 cSt
FLUID CONTAMINATION	ISO 4406:1999 Class 20/18/15		

INSTALLATION

The configurations with centering and offset springs can be mounted in any position without impairing correct operation; instead, those without springs and with mechanical detent must be mounted with the longitudinal axis horizontal.

Valves are fixed by means of screws or tie rods on a flat surface with planarity and roughness equal to or better than those indicated in the relative symbols. If minimum values are not observed, fluid can easily leak between the valve and support surface.

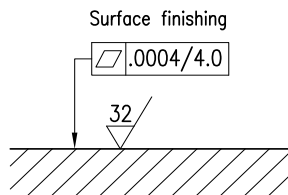

BOLT KITS

D05 SIZE	BD05H -150 - B	Valve Only	1009397
D07 SIZE	BD07 - 250	Valve Only	1009400
D08 SIZE	BD08 - 275	Valve Only	250141
D10 SIZE	BD10 - 275	Valve Only	1013038

SEAL KIT

D05* SIZE	Buna Seal Kit	1013966
	Viton Seal Kit	1013967
D07 SIZE	Buna Seal Kit	1013968
	Viton Seal Kit	1013969
D08 SIZE	Buna Seal Kit	1013970
	Viton Seal Kit	1013971
D10 SIZE	Buna Seal Kit	1013972
	Viton Seal Kit	1013973

SUBPLATES

D05 alt. A SIZE	AD05JESPS16S	Aluminium	SAE-16	351716AJ
	DD05JESPS16S	Ductile	SAE-16	351716AK
D07 SIZE	AD07SPS016S	Aluminium	SAE-16	1013039AB
	DD07SPS016S	Ductile	SAE-16	1013039AC
D08 SIZE	AD08SPS020S	Aluminium	SAE-20	265803AP
	DD08SPS020S	Ductile	SAE-20	265803AL
D10 SIZE	AD10SPS032S	Aluminium	SAE-32	1013040AB
	DD10SPS032S	Ductile	SAE-32	1013040AC

NOTES:

1. Max pressure for aluminum subplates: 3000 psi (210 bar)
2. Max pressure for ductile subplates: 5000 psi (350 bar)
3. Always verify subplate port size is proper for the application

POWERFUL
ACCURATE
INNOVATIVE
PRECISE
DURABLE
EFFICIENT
VERSATILE

ABOUT CONTINENTAL HYDRAULICS

Rugged, durable, high-performance, efficient—the reason Continental Hydraulics' products are used in some of the most challenging applications across the globe. With a commitment to quality customer support and innovative engineering, Continental's pumps, valves, power units, mobile and custom products deliver what the markets demand. Continental has been serving the food production, brick and block, wood products, automotive and machine tool industries since 1962. Learn how our products survive some of the most harsh environments.

SALES@CONTHYD.COM

4895 12th Avenue East, Shakopee, MN 55379 / continentalhydraulics.com / 952-895-6400

CONTINENTAL



HYDRAULICS